

INTRODUCTION

HB-LV-PIR™ offers an innovative and affordable option to add motion/photo sensing 0-10V Dim-to-Off type LED drivers in high ceiling applications. HB-LV-PIR™ is used to achieve optimal energy efficiency and is recommended on a per fixture basis. Installation is a fast and simple process. After install, simply download the SMART BLU™ App and program your lights. Applications include warehouses, gymnasiums, trade show halls, etc... A perfect choice for architects, engineers, contractors and end users.

CONSTRUCTION

Light weight and robust injection moulded polycarbonate housing and lens.

FLEXIBLE ELECTRICAL STANDARD FEATURES

HB-LV-PIR™ is classified as a low voltage product and is fed with either 12V DC auxillary output from LED driver or via the XeR™ 120/347V to 12V DC autotransformer accessory. <1mA.

PERFORMANCE

HB-LV-PIR™ includes passive infrared motion sensing technology along with a photocell for daylight control. Suitable for -20°C to +40°C ambient temperatures. 5 year standard warranty.

MOUNTING

HB-LV-PIR™ comes with a threaded nipple and locknut for mounting to standard fixture 7/8" diameter knockouts.

COMPLIANCE

RoHS, CE.

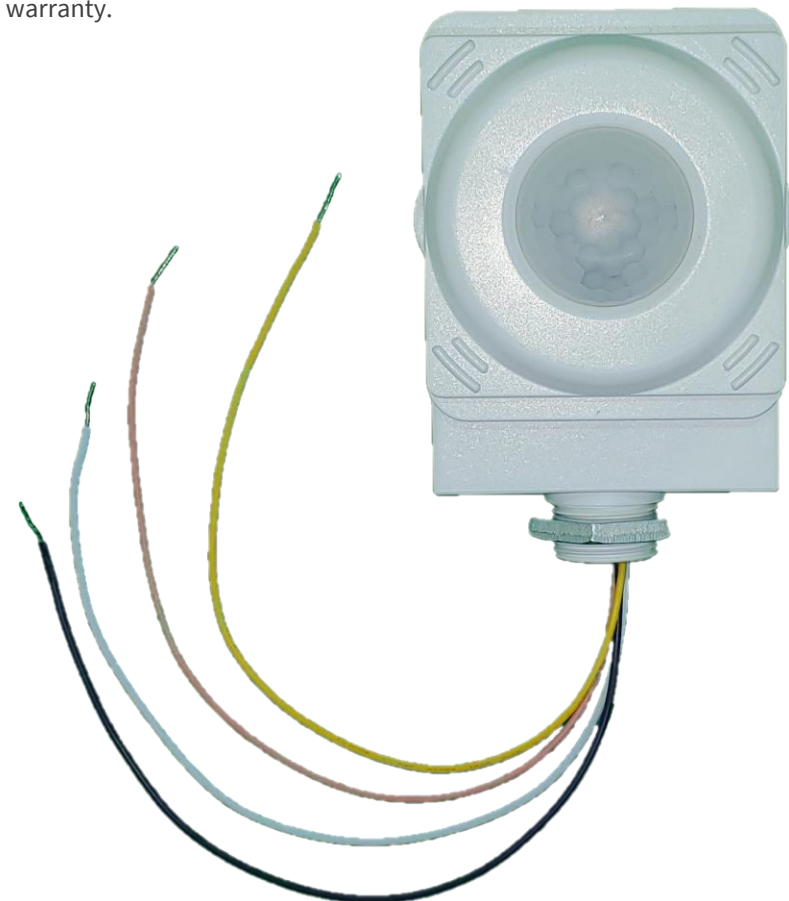

Visit www.blu-ecosystem.com for more information.

SIMPLE. AFFORDABLE. EFFECTIVE.

NOMENCLATURE

FAMILY SERIES

HB-LV-PIR

Mini-PIR™ DIMENSIONS

HOUSING

3.75" Long (nipple adds 0.625") x 2.75" Wide x 2.06" Deep

WIRES

24"



Minor Motion



Major Motion

High Bay
360°

Top View

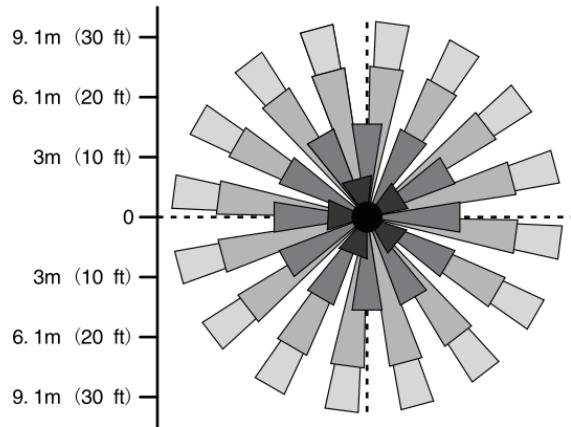

Side View

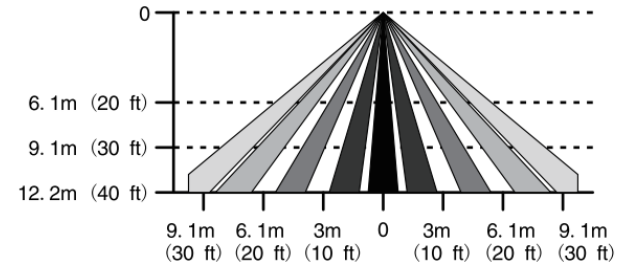

J2 Light® Version 230110

Contact your local supplier or representative or call J2 Light Inc. direct at:

1.888.LOW.WATT (569.9288) www.blu-ecosystem.com

SIMPLE. AFFORDABLE. EFFECTIVE

BLU Ecosystem™
Wireless lighting control system.

BBR-LV-HB

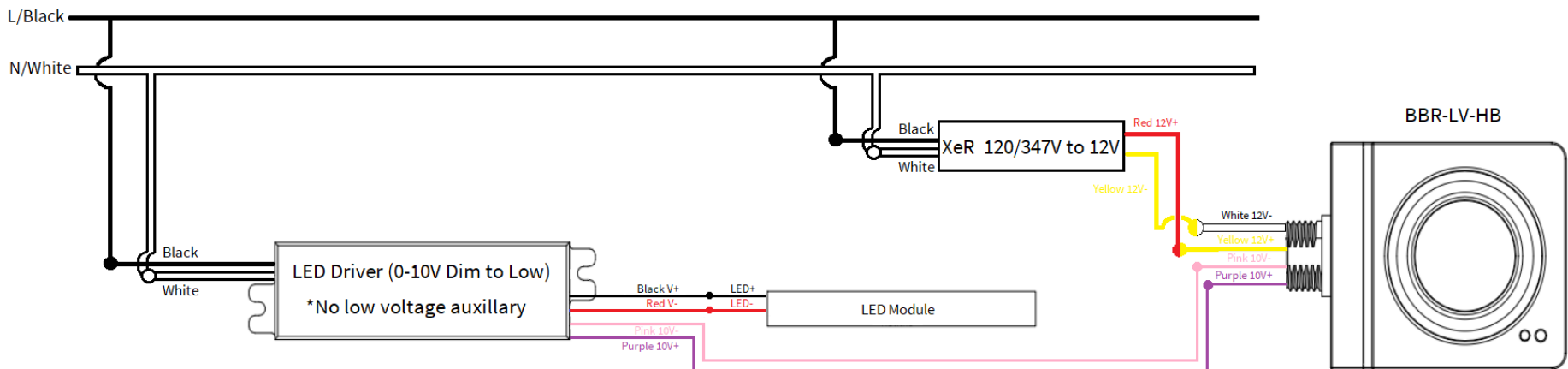
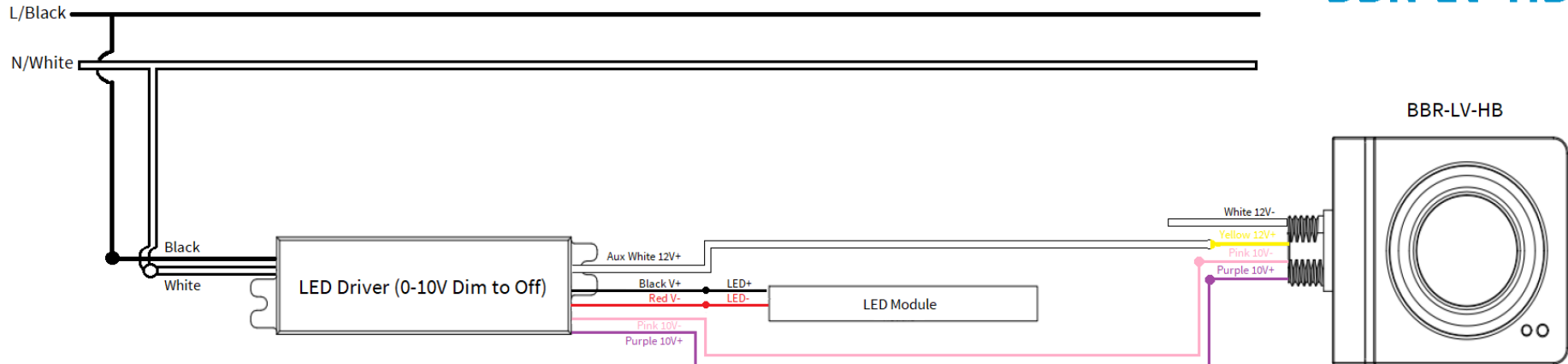

SMART
BLU
CLOUD



J2 Light® Version 230110

Contact your local supplier or representative or call J2 Light Inc. direct at:

1.888.LOW.WATT (569.9288) www.blu-ecosystem.com

SIMPLE. AFFORDABLE. EFFECTIVE